

# Lafaek



Ki'ik

Edisaun 2/2015

Ba Pre-Eskolár no Klase 1 to'o 2 E.B.



Ministériu Edukasaun Ho CARE Internasionál Iha Timor-Leste Ho Apoiu Husi Programa Asisténsia Nova Zelândia, Kolabora Hamutuk Hodi Serbí Ba Kualidade Edukasaun Ne'ebé Di'ak Iha Timor-Leste.

**Editoriál:**

**Koordenadór Programa Edukasaun** Shoab Danish

**Jestór Projektu** Simplicio Lopes Barbosa

**Vise-Jestór Projektu** Jaime de Jesus Amaral

**Koordenadór Produsaun** Octavio dos Santos Carmo de Andrade

**Supervisór M&E** Marcelino de Jesus da Costa

**Konsellu Editoriál**

Care Internasionál Iha Timor-Leste

Programa Asisténsia Nova Zelândia

Ministériu Edukasaun RDTL

**Hakerek-na'in**

Alianca M. do Rego, Aguida J. de Araujo, Joanico C. Marques,

Herminia da Costa Fernandes

**Artista**

Antoninho Ramalho, Mariano Peregrinho Noronha

**Lay-out**

Gualter Vicente José Barreto Soares

**Ofisiál-Administrasaun**

Cecilia da Silva Pinto

**Ofisiál-Finansa**

Delfrida Gomes da Conceição

**Distribuisaun**

Adriano Martins (Aileu-Ainaro), Camilo Boavida (Baucau), Geremias Noronha (Bobonaro), Anito Mau (Covalima), Eduardo Hornai (Dili-Liquiça), Joni Dana dos Santos (Ermera), Heraldo da Costa (Lautem), Eduardo Viegas (Manufahi-Manatuto), Baptista Punef (Oecuse), João da Costa (Viqueque), ONG Lokál Roman Luan (Atauro)

**Xofér**

Caetano Amaral, Nicorah Besi Campe, Adonasi Rocha da Costa,

Almerindo F. Lemos

Tetun ne'ebé uza, tuir padraun Institutu Nasionál Linguística Nian

**Enderesu** : Care Internasionál iha Timor-Leste, Bairro-Pite, Dili

**Telefone** : 3321 407

**Email** : info.lafaek@careint.org

©Labele kopia buat ne'ebé iha Revista ne'e nia laran, se laho lisensa husi CARE.

Fotografia sira iha revista ne'e, hasai husi ekipa Lafaek.

**Pájina:**

Ha'u-nia Pájina 3



Istória Badak 4-7



Koñese Letra 8-9



Jogu Literasia 10



Knaar 11



Jogu Tau Kór 12

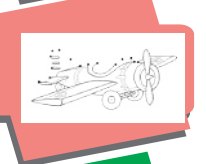

Saúde 13



Jogu Matemátika 14-15



Foto Istória 16-17



Kreatividade 18



Jogu Buka dalan 20

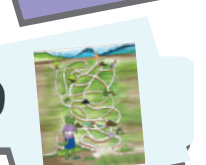





# Ha'u-nia Pájina



Alin sira, imi bele haruka imi-nia dezeñu no fotografia liuhusi belun Lafaek iha imi-nia rai.

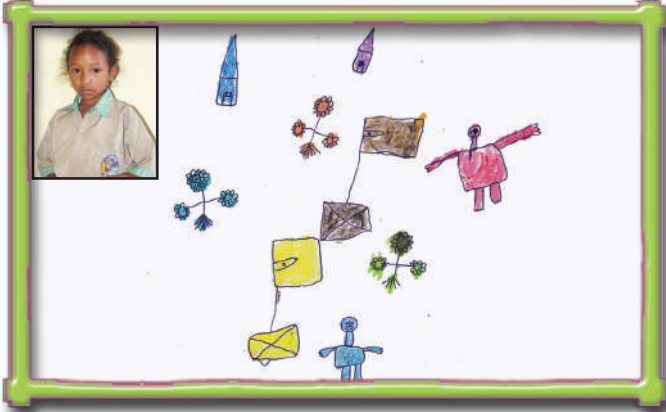

Naran : Eufrasia da Conceição  
Tinan : 7  
Klase : 1  
Eskola : E.B.F São Miguel Arcanjo, Besilau, Aileu



Naran : Abel de Araujo  
Tinan : 7  
Klase : 1  
Eskola : E.B Riamori, Maubisse, Ainaro

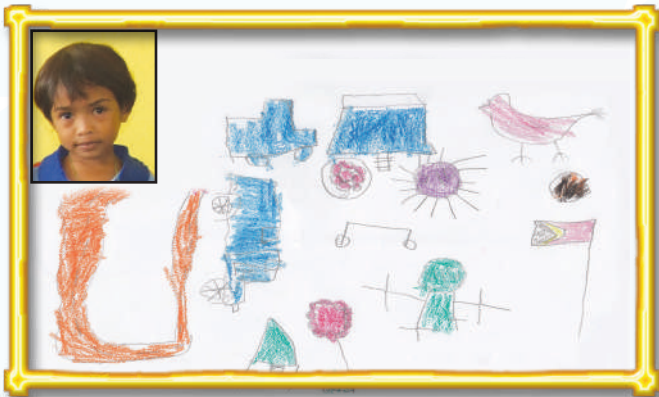

Naran : Gaspar V.A. Pereira Mendonça  
Tinan : 5  
Eskola : Pre-eskolár Nio Rosalia, Balibar, Dili

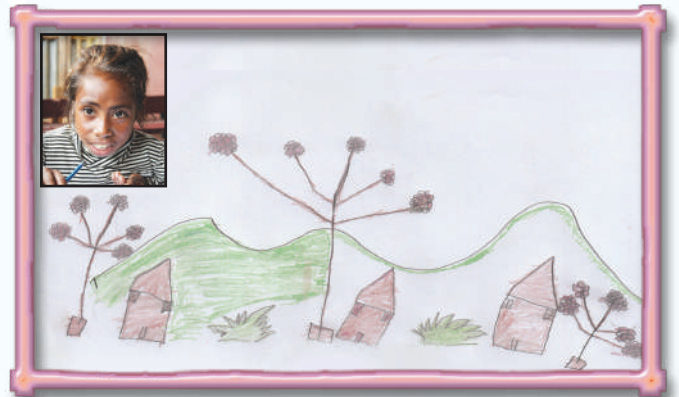

Naran : Imaculada Barreto  
Tinan : 8  
Klase : 2  
Eskola : E.B Riamori, Maubisse, Ainaro



Naran : Rozelia Baptista Soares  
Tinan : 5  
Klase : 1  
Eskola : Pre-eskolár Nio Rosalia, Balibar, Dili



Naran : Domingos Barreto  
Tinan : 8  
Klase : 2  
Eskola : E.B Riamori, Maubisse, Ainaro

Maun Lafaek sei hili dezeñu ne'ebé furak atu tau iha revista.



# Asika Mehi Sai Pilotu

1

Mauno, Beloi, Asika, Mausoko, Lafaek Nina no Lafaek Ki'ik halimar.



2

Asika haree aviaun semo. Nia hatudu ba aviaun ne'e.







3

"Ha'u hakarak sai pilotu," Asika dehan.

4

Asika hatutan,  
"Bainhira sai pilotu,  
ha'u bele tula imi  
semo iha lalehan."



5

"Ha'u mós bele tula  
imi semo ho manu  
sira."





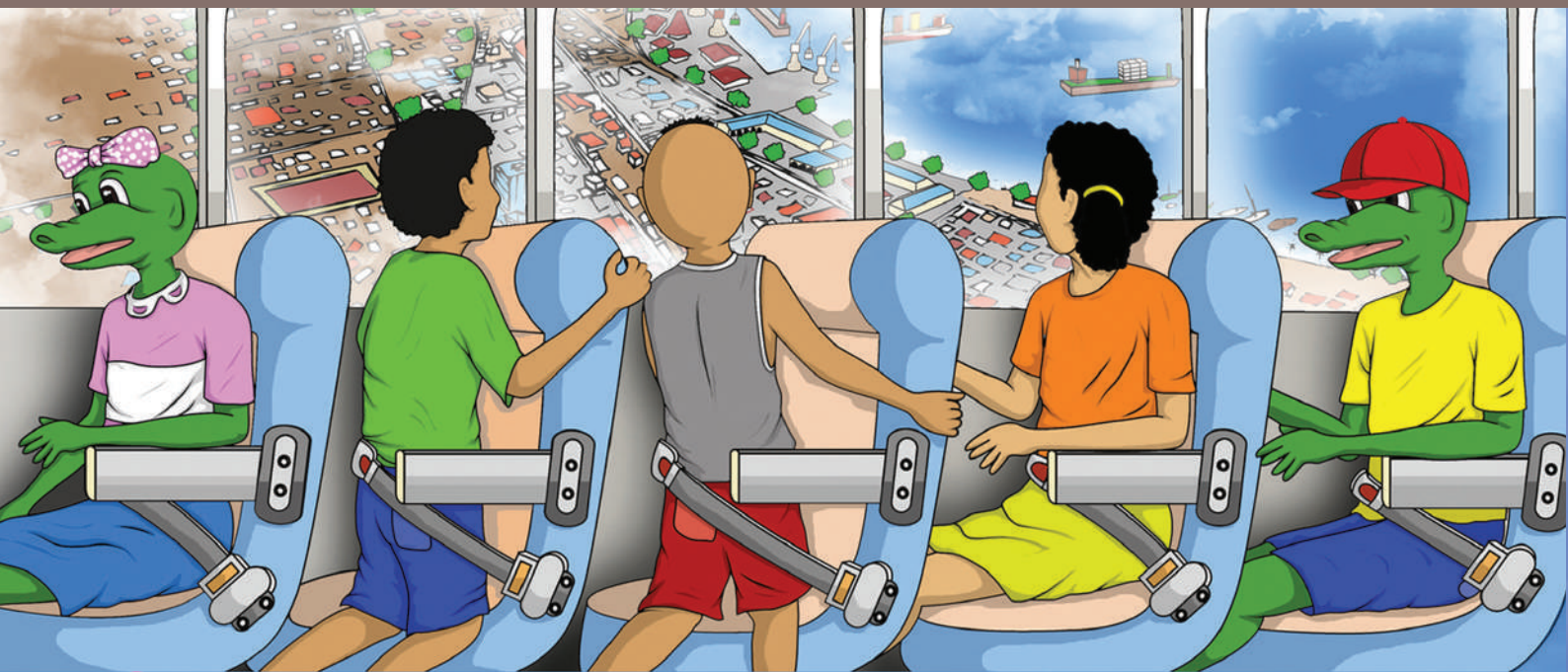

6 "Husi lalehan ita bele haree rai oioin ne'ebé furak."



7

"Ita bele bá pasiar iha mundu tomak."

8

Maibé, Lafaek Nina hatán, "Atu sai pilotu tenke estuda maka'as."





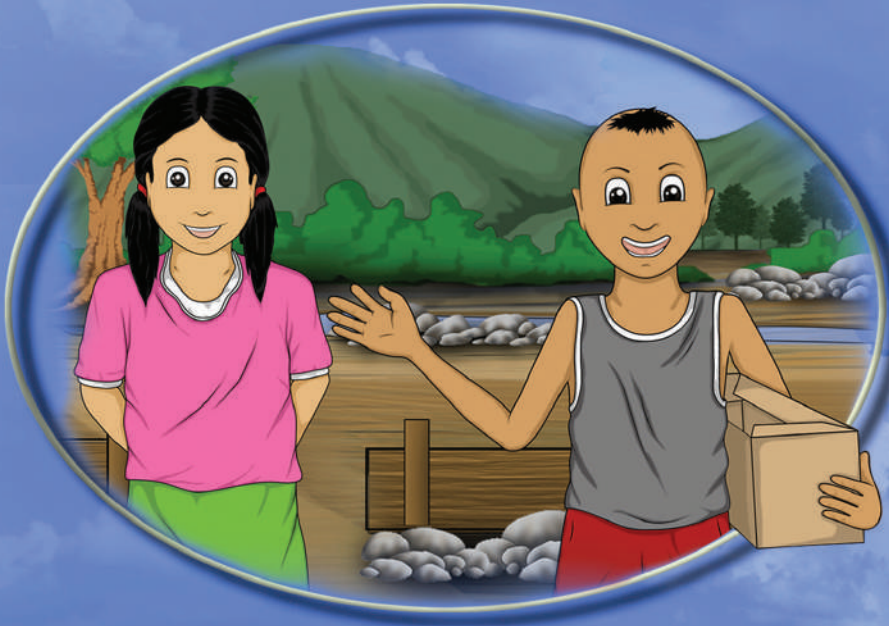

9

"Mai ita estuda hamutuk  
atu hetan ita-nia mehi,  
"Mauno dehan.

10

Sira estuda hamutuk  
iha grupu.



11

Ikusmai, sira halimar  
sa'e aviaun. Asika maka  
sai pilotu. Sira hotu kontente.





# Mai Koñese Letra Ho Mausoko

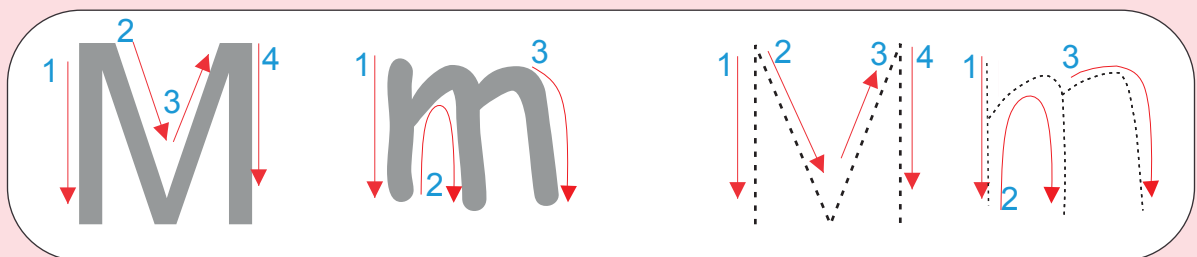
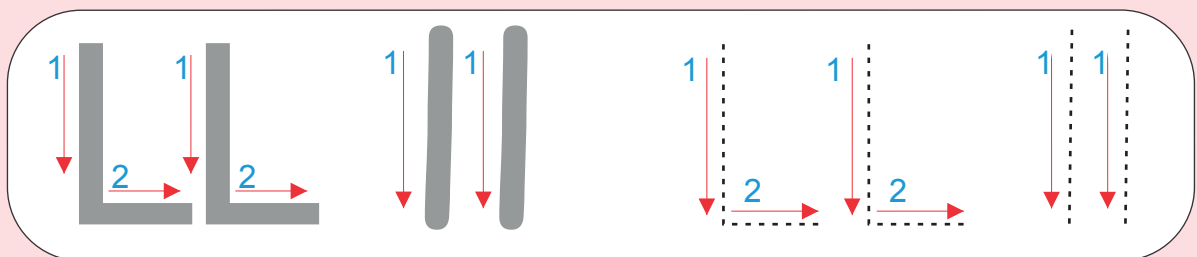
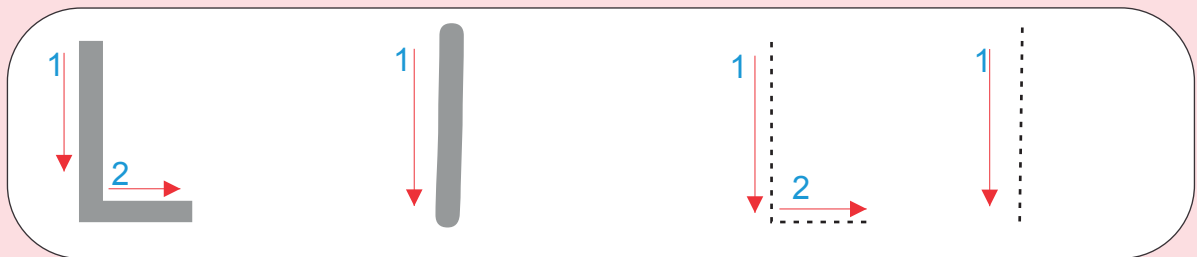
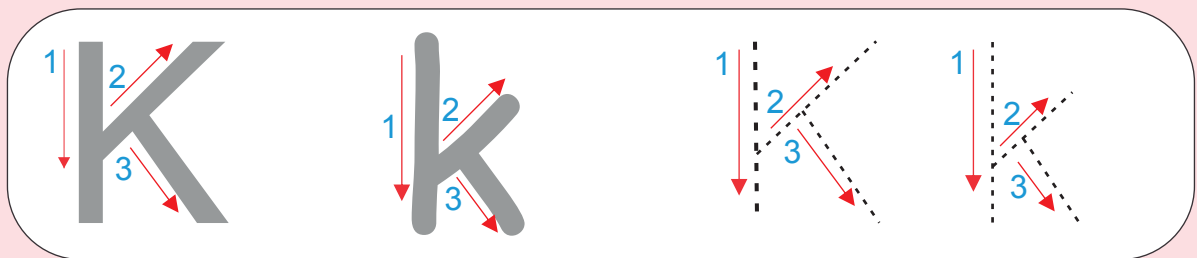
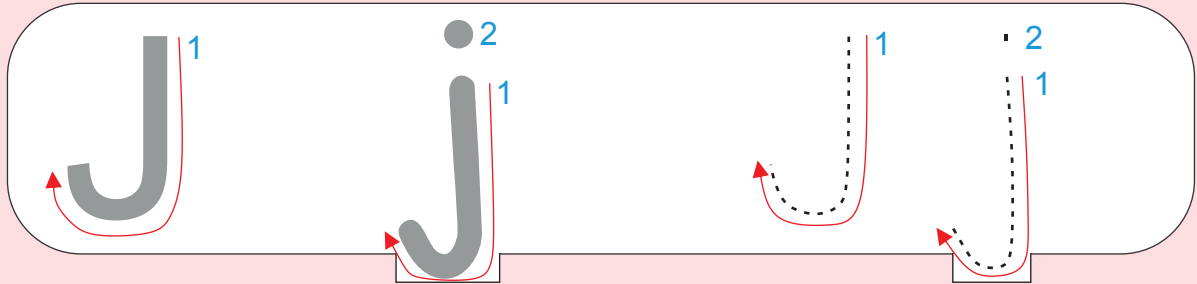



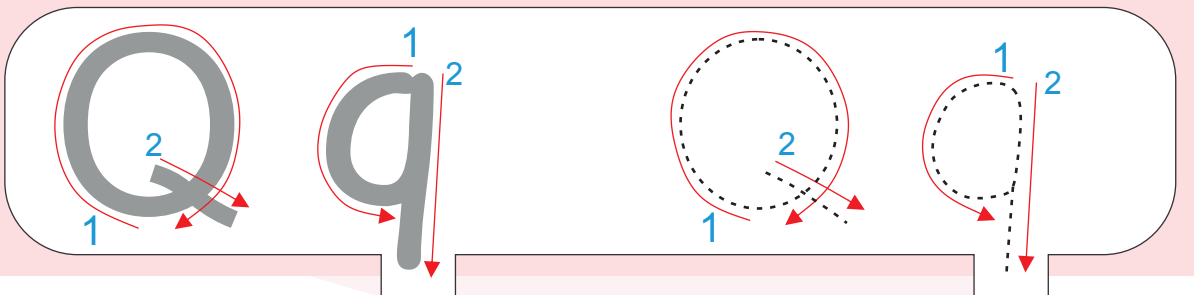
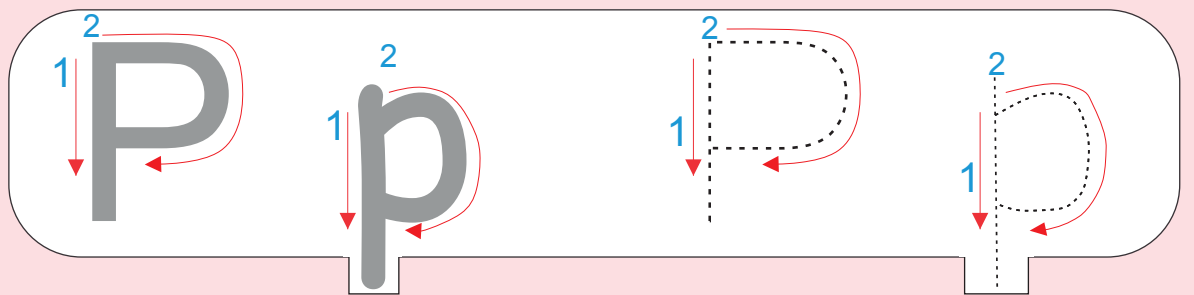
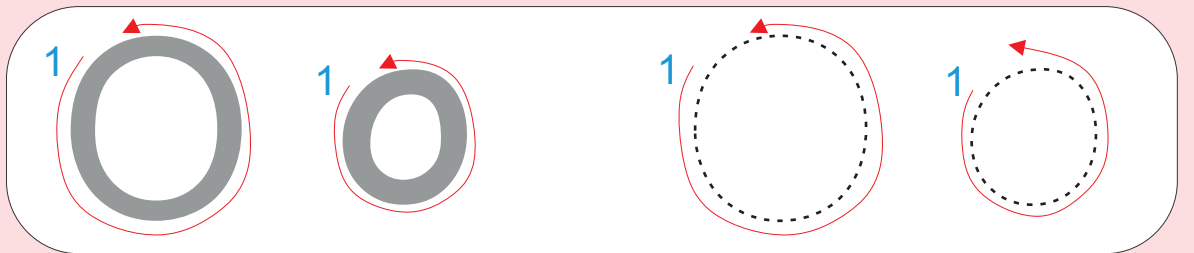
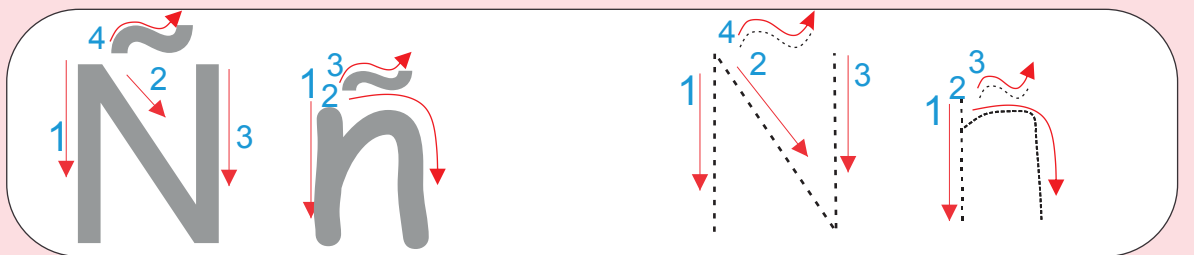
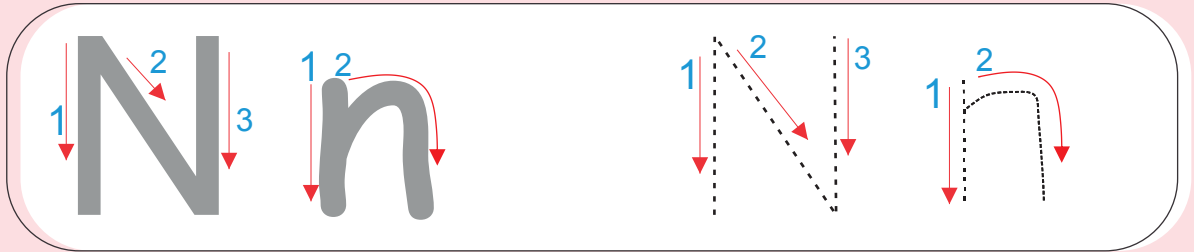

Letra Q uza de'it ba ema, balada no rai nia naran.

# Forma Liafuan

j — j**anela** — janela



k — k**adeli** — kadeli



l — l**aho** — laho



ll — t**oalla** — toalla

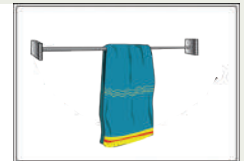

m — m**odo** — modo



n — n**ehan** — nehan

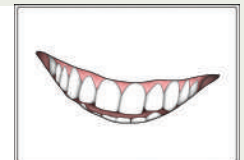

ñ — v**entuiña** — ventuiña

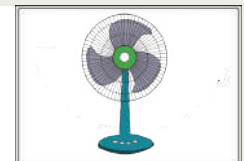

o — o**in** — oin



p — p**illa** — pilla



q — q**ui** — qui

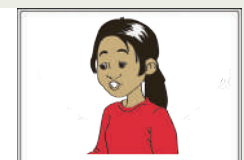



# Knaar



**Doutór**  
Ha'u kura ema moras.



**Pilotu**  
Ha'u lori aviaun.



**Mekániku**  
Ha'u hadi'a karreta.



**Xofér**  
Ha'u lori karreta.

Kompleta tuir letra ne'ebé seidak moos iha kuadru laran.

**Ezemplu :**

	m							
	e							
	k			d				
	á		x	o	f	e	r	
	n			u				
	i		o	t	u			
	k			ó				
	u			r				

Hmm...Ó hakarak sai saida kolega ?

# Mai Pinta hō Mauno



Dada Liña husi número 1 to'o 15.  
Tau kór oioin atu sai furak liután!

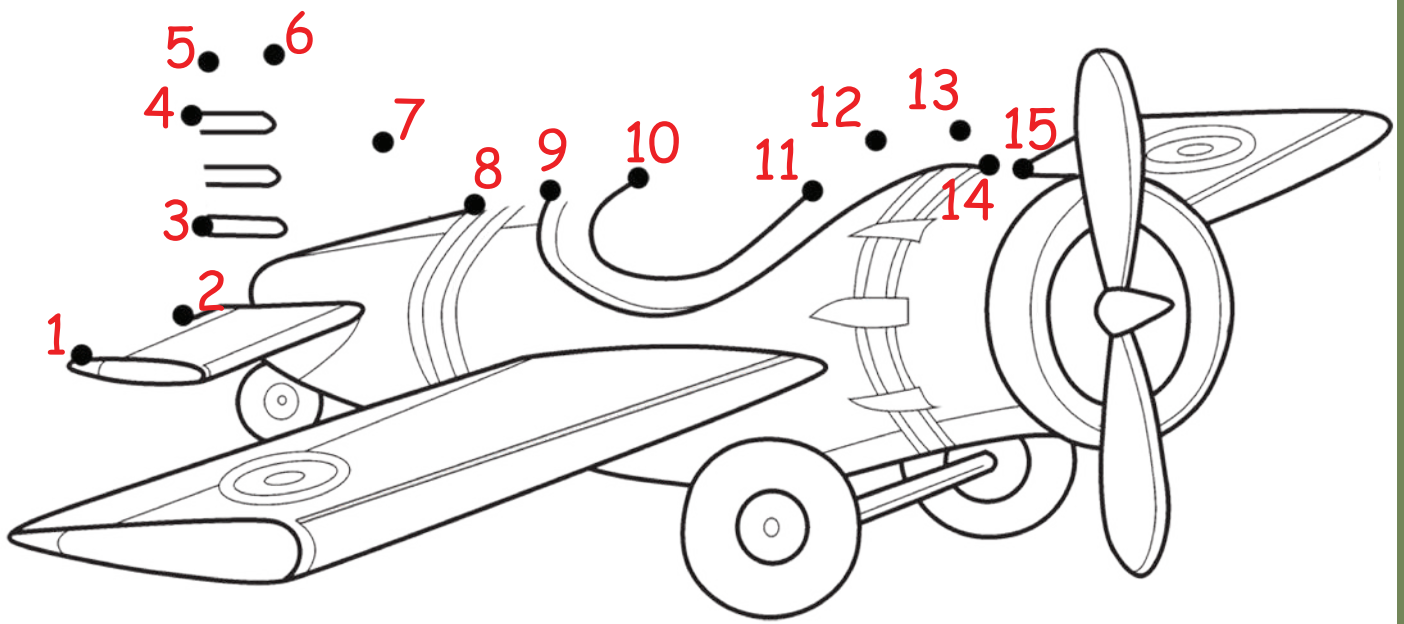



# Ai-han ne'ebé di'ak ba ki'ik-oan sira



Ai-han fó protesaun

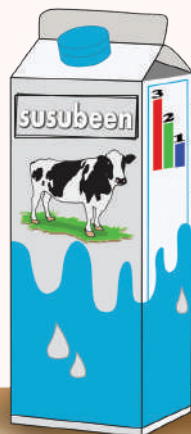

Isin di'ak no forte

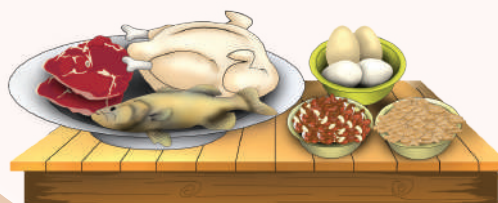

Ai-han haburas



Ai-han fó forsa



Konsentra ho di'ak



Iha forsa hodi han no halimar

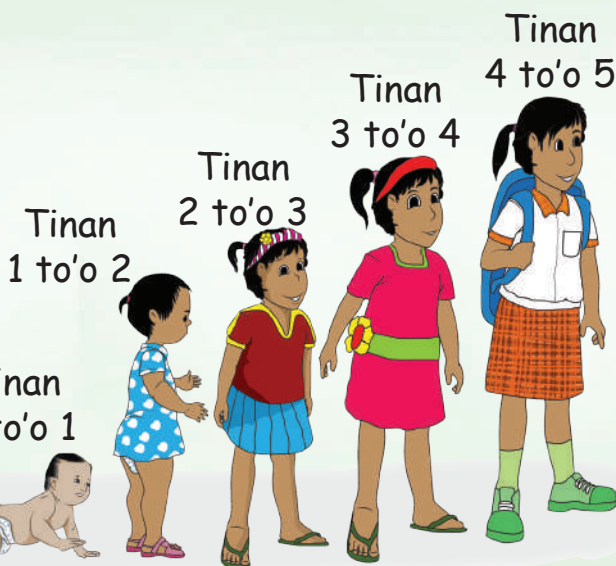

Tinan 0 to'o 1

Tinan 1 to'o 2

Tinan 2 to'o 3

Tinan 3 to'o 4

Tinan 4 to'o 5



Halimar ho di'ak



Forsa hodi halai

Boot tuir idade

Di'ak liu, han ai-han ho kór oioin tanba bele fó forsa ba ita.

# Figura Jeométrika



Mai ita aprende figura jeométrika ho Lafaek Nina

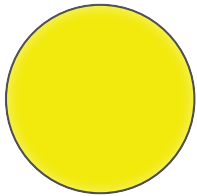

Sírkulu



Kuadradu

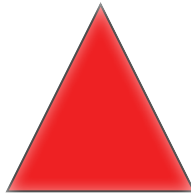

Triángulu



Retángulu

Ne'e maka sírkulu.



Relójiu ne'e mós sírkulu.



Ne'e maka kuadradu.



Prémiu ne'e mós kuadradu.



Ne'e maka triángulu.



Réguu ne'e mós triángulu.



Ne'e maka retángulu.



Revista ne'e mós retángulu.







Kuadradu iha sikun haat ne'ebé naruk no luan hanesan.



Sírkulu maka kabuar, haree hanesan relójiu.



Triángulu iha sikun tolu ne'ebé mak hanesan.



Retángulu atu hanesan kuadradu maibé nia naruk no luan la hanesan.

## Mai sura sasán tuir forma sira iha okos ne'e!

Ezemplu: Sírkulu 3

Retángulu.....?

Kuadradu.....? Triángulu.....?



Sírkulu



Sírkulu



Sírkulu



Triángulu



Kuadradu



Kuadradu



Retángulu

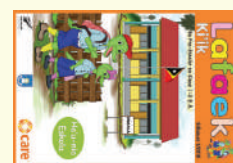

Retángulu



# Ha'u ho Kolega

Ha'u Iban. Ha'u iha kolega foun.  
Sira gosta halimar ho ha'u.  
Mai ita koñese sira.



1

Ne'e ho Alia. Ha'u aas liu Alia



2

Ne'e ho Tuta. Tuta nia faru kór mutin, ha'u-nia kalsa kór metan.



3

Ne'e mak Nina. Nina nia fuuk naruk, ha'u fuuk badak.



4

Ne'e ho Lina. Lina aas liu fali ha'u.





5

Alia gosta pinta.



6

Tuta gosta halimar ho ai-funan.



7

Nina gosta hakso'it tapa.



8

Lina gosta baku manu-fulun.



9

Ami halimar ho kontente.

Hai kolega, hakerek saida maka ita gusta.

.....



# Tapa Tuir Ai-Tahan

Mai hamutuk ho Biloi halo kriatividade iha kraik ne'e.



Prepara Surat-tahan,  
Lapis no ai-tahan.



Ne'e maka ai-tahan ne'ebé atu tapa tuir.



Tau surat-tahan iha ai-tahan nia leten hodi tapa-tuir.



Tapa tuir ai-tahan ne'e uza lapis.



Ikusmai kose ho lapis to'o sai forma ai-tahan.



# Buka Dalan

Mai tulun Lafaek Nina buka nia busa oan!





# Lafaek nia Kolega



Kolega sira-ne'e husi Aileu ho Ainaro.